

SPECIAL SERVICE TOOLS

OMC has specially-designed tools to simplify some of the disassembly and reassembly operations. These tools are illustrated in this Service Manual, in many cases in actual use. Refer to the Special Service Tool Catalog for a description and ordering instructions for these tools. Purchasers of individual manuals must order Special Tools through an authorized dealer.

OUTBOARD MOTOR NOMENCLATURE

Sometimes the words "right" and "left" are very confusing when referring to the sides of an outboard motor. Therefore, the sides are referred to as STARBOARD or PORT sides. STARBOARD means on the right hand while facing the bow (FRONT) of the boat; PORT means left hand. See Figures 1-1 and 1-2.

Service required for the motor is generally one of three kinds . . .

1. **NORMAL CARE AND MAINTENANCE**, which includes putting a new motor into operation, storing motors, lubrication, and care under special operating conditions such as salt water and cold weather.
2. **OPERATING MALFUNCTIONS** due to improper motor mounting, propeller condition or size, boat condition, or the malfunction of some part of the motor. This includes motor tune-up procedures to keep the motor in prime operating condition.
3. **COMPLETE DISASSEMBLY** and overhaul, such as inspecting a motor that has been submerged or rebuilding trade-in units.

It is important to you as the service man to determine before disassembly just what the trouble is, and how to correct it quickly and with minimum expense to the owner. This section of the manual is designed to help you diagnose motor malfunctions and correct them.

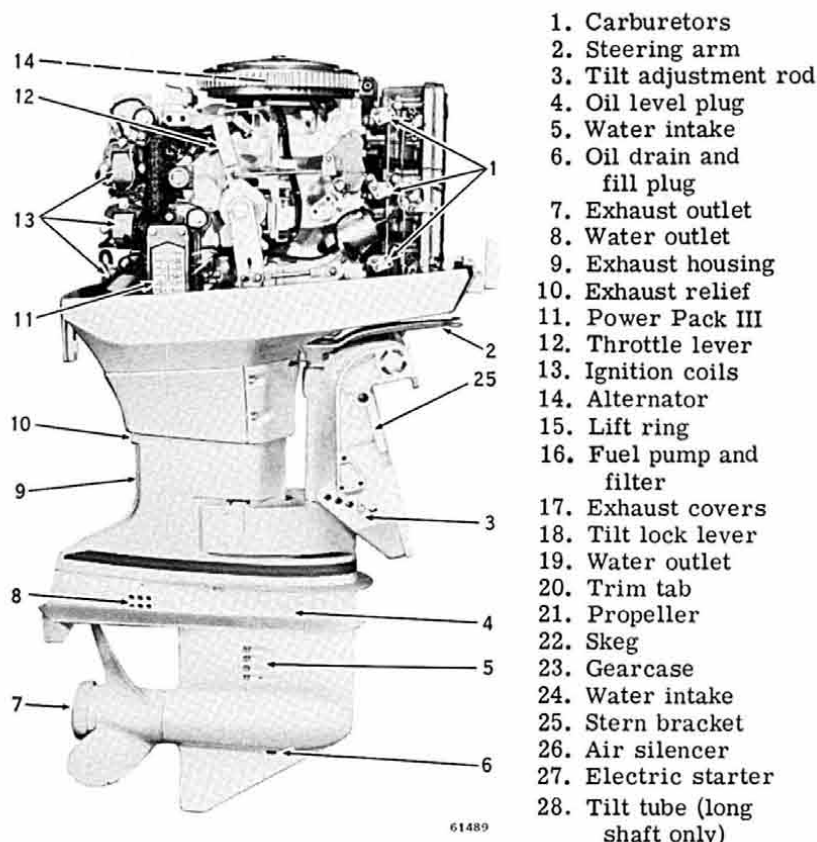

Figure 1-1. Starboard View
(Standard Length)

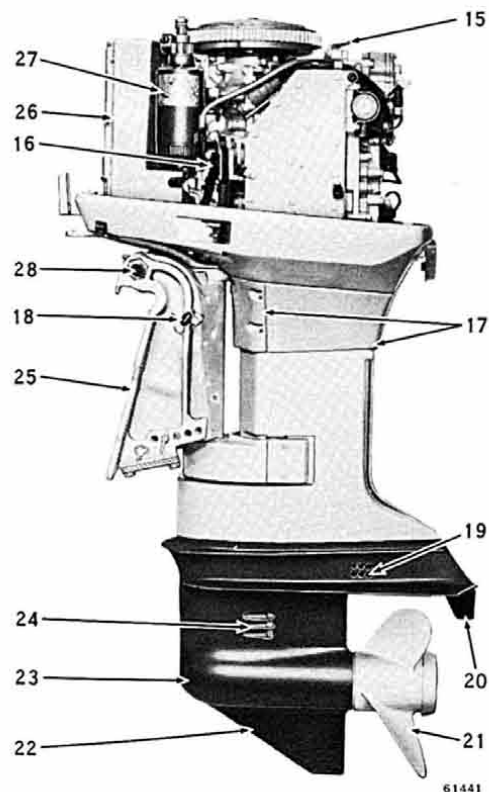

Figure 1-2. Port Side View
(Long Shaft Model)