

1970 MODEL

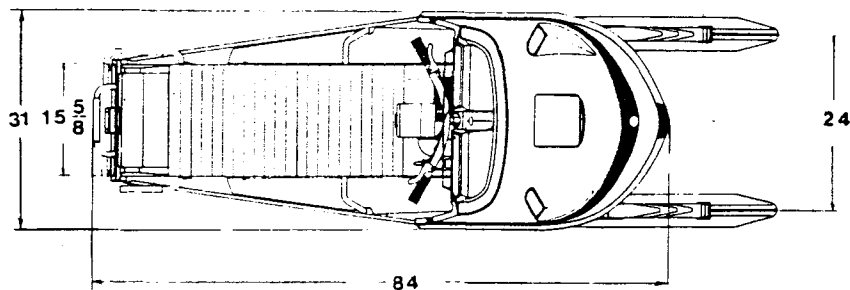

1970 OLYMPIQUE SPECIFICATIONS

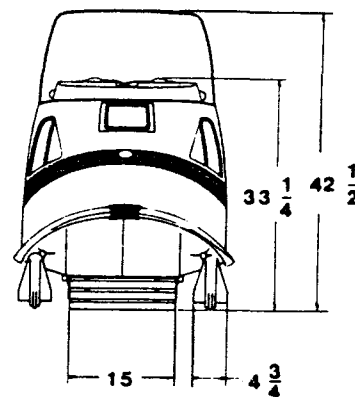
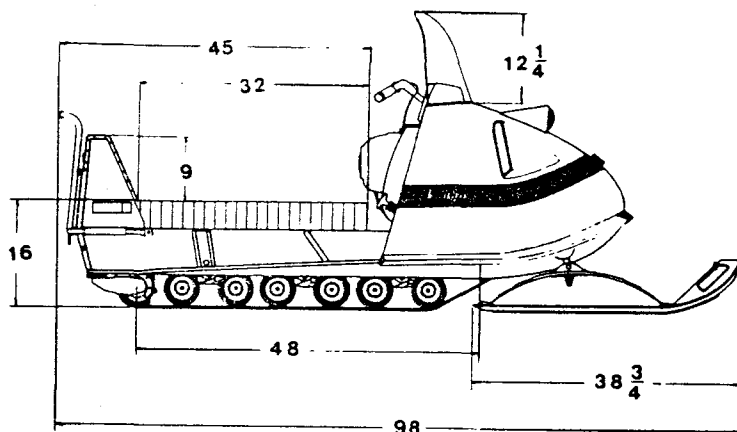

ITEM	OLYMPIQUE	12/3	335	335/E	399
ENGINE	No. of Cylinders	ONE	ONE	ONE	TWO
	Bore	76 M.M.	78 M.M.	78 M.M.	2x64.5 M.M.
	Stroke	66 M.M.	70 M.M.	70 M.M.	2x61 M.M.
	Displacement	299.4 c.c.	334.5 c.c.	334.5 c.c.	398.6 c.c.
	Compression Ratio	6.5:1	7.5:1	7.5:1	8.75:1
CHASSIS	Overall Length	98"	98"	98"	98"
	Overall Width	31"	31"	31"	31"
	Height W/O Windshield	33-1/4"	33-1/4"	33-1/4"	33-1/4"
	Weight (Lbs.)	295	300	335	320
	Bearing Area	1092 sq. in.	1092 sq. in.	1092 sq. in.	1092 sq. in.
	Ground Pressure (P.S.I.)	.270	.275	.306	.293
POWER TRAIN	Track (Width)	15"	15"	15"	15"
	Standard Gear Ratio	10/25	11/25	11/25	16/34
IGNITION	Starting	Manual	Manual	Electric	Manual
	Lighting Coil (Watts)	40W	40W	75W	75W
	Spark Plug(s) Bosch	M-240-T-1*	M-240-T1*	M-240-T-1*	W-240-T-1*
	Spark Plug (Gap)	.020"	.020"	.020"	.020"
	Breaker Points (Gap)	.014"-.018"	.014"-.018"	.014"-.018"	.014"-.018"
FUEL	Tank Capacity – Imp.	3 gal.	3 gal.	3 gal.	3 gal.
	Tank Capacity – U.S.	3.75 gal.	3.75 gal.	3.75 gal.	3.75 gal.
	Mixing Ratio (Gas/Oil)	20:1	20:1	20:1	20:1
BRAKE	Type	Drum	Drum	Drum	Drum
ACCES- SORIES	Speedometer	Optional	Optional	Optional	Optional
	Tachometer	Optional	Optional	Optional	Optional

*When ordering replacement spark plug(s), specify number shown above.